

LARGE SGA SERIES OZONE/OXYGEN SYSTEMS

Features

- Stainless Steel Floor Mount Enclosure
- Air-Cooled Ceramic and Titanium Reactor Cell
- Onboard Oxygen Concentrator
- 0.01 Micron Filter/Regulator with Auto Drain
- Over-Temperature Protection

Controls

- 4-20mA or 0-10VDC Input
- Variable Output Control
- Feed Gas Flow Control
- Remote On/Off Control
- Power Supply Control Signal Reference Meter
- Reactor Pressure Control
- Reactor Pressure Gauge
- Air Input Pressure Gauge
- Remote Lockout

High Ozone Output

The Large SGA Series of integrated ozone/oxygen systems combines air-cooled ozone generation with onboard oxygen concentration in a compact, stainless steel housing.

Powerful and user-friendly, the Large SGA Series can produce up to 12.7 pounds of ozone/day and is ideal for a broad range of commercial and industrial applications.

User Friendly

The Large SGA Series is easy to operate with a convenient, intuitive control panel, including 0-100% variable

power control, feed gas control, inlet air pressure and reactor back-pressure gauges; power supply control signal reference meter; and LED ozone production indicators. The control interface includes 4-20mA or 0-10VDC input signal for 0-100% variable ozone concentration control.



Model: Large SGA53/63/64

LARGE SGA SERIES OZONE/OXYGEN SYSTEMS

Robust and Reliable

The heart of Pacific Ozone systems is our patented Floating Plate Technology™ in the ozone reaction cells. The exclusive FPT design produces highly reliable and efficient ozone generation in affordable, air-cooled systems. Floating Plate Technology allows challenging ozone applications and products to be approached with confidence and ease.

The Large SGA Series is designed to operate with high-quality plant air provided from the facility. Stand-alone air compressor packages are also available from Pacific Ozone if plant air is unavailable or insufficient.



SGA Series Family

The Large SGA Series is part of a family of integrated ozone oxygen systems that include the standard SGA Series with ozone production capability to 3.2 lbs./day. All SGA Series systems are engineered to meet all of the ozone process requirements found in the most demanding applications; yet, they are easy to install, simple to operate, and will provide years of trouble-free operation.

LARGE SGA SERIES OZONE/OXYGEN SYSTEMS

Model: Large SGA 43/44

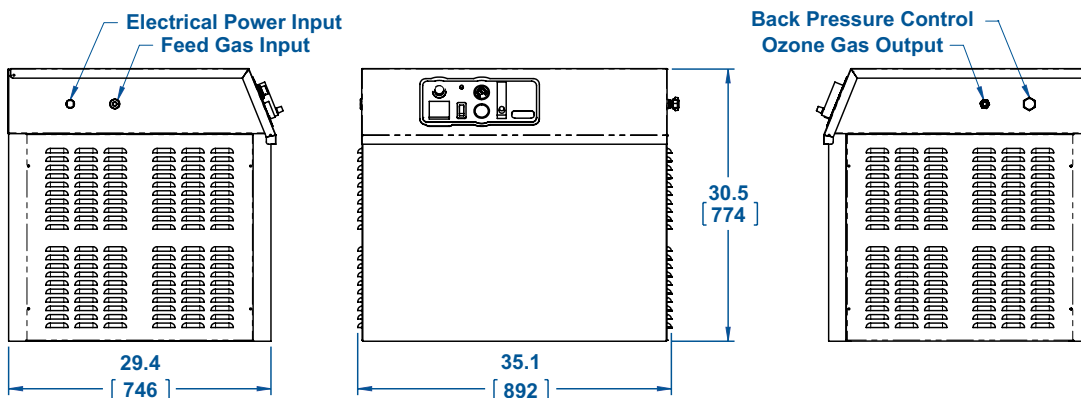

Model: Large SGA 53/63/64

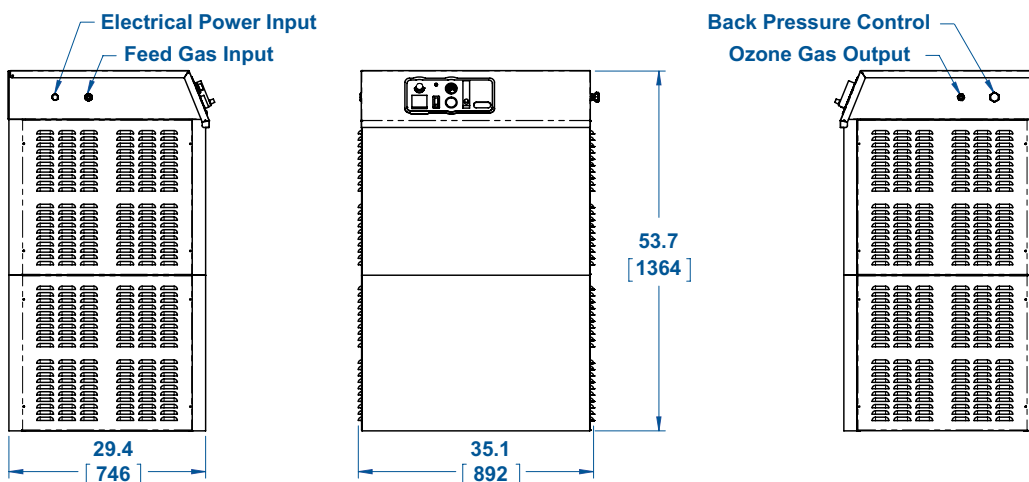

Technical Specifications

Model/ Part Number	Max. Ozone Production	Max. Ozone Concentration	Max. Reactor Pressure	Feed Gas Flow Range	Power Consumption	Air Cooling	Compressed Air Inlet Fitting	Ozone Outlet Fitting*	Dimensions (HxWxD)	Weight
	lbs./day (grams/hour)	% weight	psig (bar)	scfh (lpm)	watts	scfm (lpm)	inches (mm)	inches (mm)	inches (mm)	lbs (kg)
SGA43/ R-SGA432 (230V)	4.8 (90)	8%	12 (0.8)	10-80 (5-38)	1100	480 (13592)	1/2" fnpt (12.7 mm)	1/2" (12.7 mm)	30.5x35.1x29.4 (774x892x746)	220 (100)
SGA44/ R-SGA442 (230V)	6.3 (120)	8%	12 (0.8)	10-80 (5-38)	1200	480 (13592)	1/2" fnpt (12.7 mm)	1/2" (12.7 mm)	30.5x35.1x29.4 (774x892x746)	230 (104)
SGA53/ R-SGA532 (230V)	7.1 (135)	8%	12 (0.8)	20-120 (9-57)	2190	720 (20388)	1/2" fnpt (12.7 mm)	1/2" (12.7 mm)	53.7x35.1x29.4 (1364x892x746)	330 (150)
SGA63/ R-SGA632 (230V)	9.5 (180)	8%	12 (0.8)	20-160 (9-76)	2920	960 (27184)	1/2" fnpt (12.7 mm)	1/2" (12.7 mm)	53.7x35.1x29.4 (1364x892x746)	375 (170)
SGA64/ R-SGA642 (230V)	12.7 (240)	8%	12 (0.8)	20-160 (9-76)	3320	960 (27184)	1/2" fnpt (12.7 mm)	1/2" (12.7 mm)	53.7x35.1x29.4 (1364x892x746)	460 (209)

* Compression fitting.

LARGE SGA SERIES OZONE/OXYGEN SYSTEMS

Operational Requirements

Model/ Part Number	Compressed Air Flow	Compressed Air Pressure	Electrical Requirement
	scfm (lpm)	psig (bar)	Volts, Hz
SGA43/ R-SGA432 (230V)	24 (680)	40 (2.76)	230V 50/60Hz 1 phase 20A Circuit
SGA44/ R-SGA442 (230V)	24 (680)	40 (2.76)	230V 50/60Hz 1 phase 20A Circuit
SGA53/ R-SGA532 (230V)	36 (1019)	40 (2.76)	230V 50/60Hz 1 phase 20A Circuit
SGA63/ R-SGA632 (230V)	48 (1359)	40 (2.76)	230V 50/60Hz 1 phase 20A Circuit
SGA64/ R-SGA642 (230V)	48 (1359)	40 (2.76)	230V 50/60Hz 1 phase 20A Circuit



6160 Egret Court
Benicia, California 94510
p: (707) 747.9600
f: (707) 747.9209
www.pacificozone.com